



**QUICK RESPONSE
AUTOMATIC SPRINKLERS
GL SERIES
DRY TYPE
CONCEALED PENDENT**

DESCRIPTION AND OPERATION

The Globe Quick Response GL Series Dry Type Concealed Pendent Sprinkler is designed for use in special applications such as freezing environments and conditions where sediment or foreign materials might accumulate in ordinary drop nipples. It offers the ultimate in low profile, aesthetically pleasing appearance. All that is seen at the ceiling is a 3 5/16" diameter ceiling plate color finished to match the specifier's exact requirements. The Quick Response GL Series Dry Concealed Sprinkler may be virtually invisible as it does not interrupt the "smooth flow" of the ceiling. The quick response sprinkler offers the additional feature of greatly increased safety to life, with operation approximately six times faster than ordinary sprinklers and should be used advisedly and under the direction of approving authorities having jurisdiction. Globe's Dry Concealed Sprinkler utilizes its frangible 3mm glass bulb type sprinkler which is located above the ceiling and concealed from view by the ceiling plate. The plate is soldered to the sprinkler special upper support assembly in three places. Upon the application of sufficient heat, the plate falls to the floor exposing the pendent spray sprinkler. At the ampule's rated temperature, the sprinkler opens releasing the bulb seat, causing the inner tube assembly to move allowing the spring assembly to pivot alongside the inner tube. At this time, water flows through the sprinkler and is distributed by the deflector in an approved discharge pattern.

A special spring is attached to the pendent deflector that serves to provide a constant tension against the ceiling plate. This feature virtually ensures freedom from environmental vibration problems.

The heart of Globe's GL Series sprinkler proven actuation assembly is a hermetically sealed frangible glass ampule that contains a precisely measured amount of fluid. When heat is absorbed, the liquid within the bulb expands increasing the internal pressure. At the prescribed temperature the internal pressure within the ampule exceeds the strength of the glass causing the glass to shatter. This results in water discharge which is distributed in an approved pattern.

TECHNICAL DATA

- See reverse side for Approvals and Specifications.
- Temperature Ratings -
 - 135°F (57°C) Sprinkler, 135°F (57°C) Cover Plate;
 - 155°F (68°C) Sprinkler, 135°F (57°C) Cover Plate;
 - 155°F (68°C) Sprinkler, 155°F (57°C) Cover Plate;
 - 175°F (79°C) Sprinkler, 155°F (68°C) Cover Plate;
 - 200°F (93°C) Sprinkler, 155°F (68°C) Cover Plate.
- Water Working Pressure Rating - 175 psi (12 Bars).
- Factory tested hydrostatically to 500 psi (34 Bars).
- Maximum low temperature glass bulb rating is -67°F (-55°C).
- Frame - bronze • Deflector - brass • Screw - brass
- Bulb seat - brass • Spring - teflon coated nickel alloy
- Retainer - brass • Pin - stainless steel • Torsion spring - stainless steel
- Bulb - glass with alcohol based solution, 3mm • Orifice insert - brass
- 3/4" NPT or 1" NPT • Outer tube - galvanized steel pipe
- Inner tube - stainless steel



**QUICK RESPONSE
WHITE
DRY CONCEALED PENDENT**

• SPRINKLER TEMPERATURE RATING/CLASSIFICATION and COLOR CODING

CLASSIFICATION	AVAILABLE SPRINKLER TEMPERATURES		BULB COLOR	N.F.P.A. MAXIMUM CEILING TEMPERATURE	
	135°F/155°F	57°C/68°C		100°F	38°C
ORDINARY	135°F/155°F	57°C/68°C	ORANGE/RED	100°F	38°C
INTERMEDIATE	175°F/200°F	79°C/93°C	YELLOW/GREEN	150°F	66°C

QUICK RESPONSE AUTOMATIC SPRINKLERS GL SERIES DRY TYPE CONCEALED PENDENT

SPECIFICATIONS

NOMINAL "K" FACTOR	THREAD SIZE	LENGTH	FINISHES
5.6 (80 metric)	3/4" or 1" NPT	cULus Variable to 48"	Bright Chrome White Painted ¹ Satin Chrome ¹ Bright Brass
8.1 (116 metric)	1" NPT	FM Variable to 36"	¹ Other Painted Finishes

NOTE:
Metric conversions are approximate.

¹Finishes available on special order. Painted plates other than white require customer to furnish paint. Contact Globe for paint specification.

APPROVALS

STYLE	SIN MODEL	K FACTOR	THREAD SIZE	135° F (57° C) WITH PLATE 135° F (57° C)	155° F (68° C) WITH PLATE 135° F (68° C)	155° F (68° C) WITH PLATE 155° F (68° C)	175° F (79° C) WITH PLATE 155° F (68° C)	200° F (93° C) WITH PLATE 155° F (68° C)	* FM	cULus	NYC - DOB MEA 101-92-E
CONCEALED PENDENT	GL5637	5.6	1" NPT	X	X	X	X	X	X	X	X
	GL5638	5.6	3/4" NPT	X	X	X	X	X	-	X	X
	GL8137	8.1	1" NPT	X	X	X	X	X	-	X	X

NOTE:

Listed for ALL hazards.

* Concealed Pendent style - FM Approvals 135° F Cover & 155° F Sprinkler; 155° F Cover & 200° F Sprinkler

* FM Approved as Standard Response.

CROSS SECTION

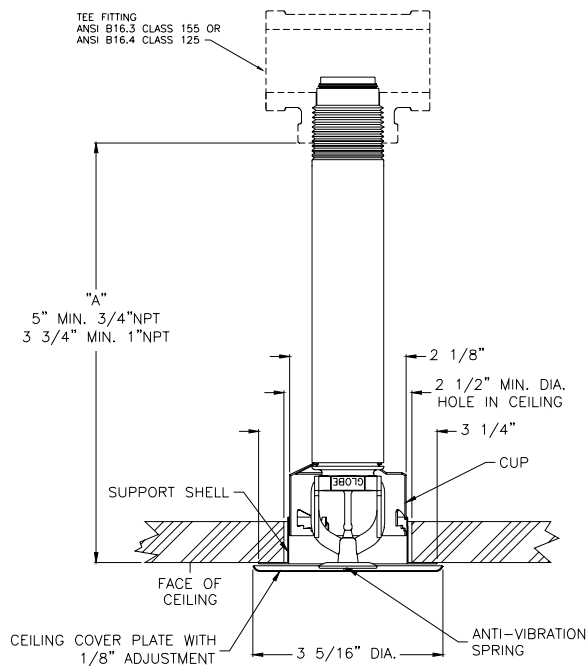

CONCEALED PENDENT

IMPORTANT INSTALLATION DATA

Globe GL Series Dry Concealed sprinklers should be installed in accordance with the requirements set forth in NFPA 13. These sprinklers are to be installed using a pipe wrench applied to the outer tube. When this is not possible, the proper sprinkler head wrench may be used with extreme care for lengths up to approximately 18". Excessive force may distort the frame thus destroying the unit.

For further important installation data, please refer to our Dry Sprinkler Caution Sheet.

ORDERING INFORMATION

SPECIFY

- Quantity • Model Number • Style
- Orifice • Temperature • Finishes desired
- Quantity - Concealed Wrenches - P/N 337014
- Quantity - Protective Caps - P/N 327119
- "A" Dimension - Distance from face of fitting to the finished ceiling line regardless of escutcheon used.

GLOBE® PRODUCT WARRANTY

Globe agrees to repair or replace any of its own manufactured products found to be defective in material or workmanship for a period of one year from date of shipment.

For specific details of our warranty please refer to Price List Terms and Conditions of Sale (Our Price List).
4077 AIRPARK DRIVE, STANDISH, MICHIGAN 48658

989-846-4583

FAX 989-846-9231

1-800-248-0278

www.globesprinkler.com

