



Colt™ Series C200, C200N

Double Check Valve Assemblies

Sizes: 2½" – 10" (65 – 250mm)

LEAD FREE*

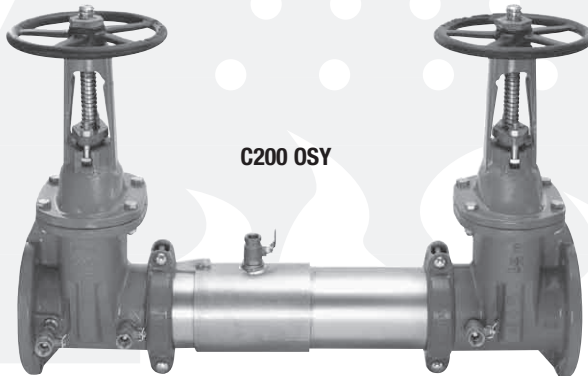

C200 OSY

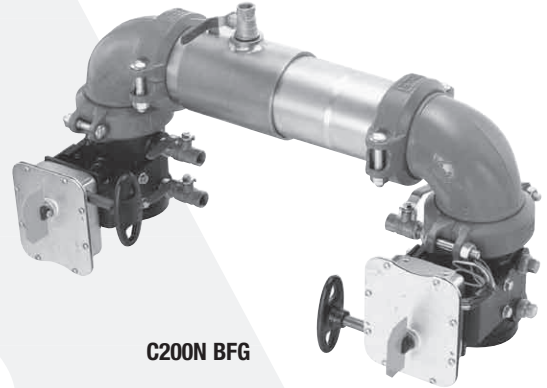

C200N BFG

Features

- Extremely Compact Design
- 70% Lighter than Traditional Designs
- 304 (Schedule 40) Stainless Steel Housing & Sleeve
- Groove Fittings Allow Integral Pipeline Adjustment
- Patented Tri-Link Check Provides Lowest Pressure Loss
- Unmatched Ease of Serviceability
- Available with Grooved Butterfly Valve Shutoffs
- Available for Horizontal, Vertical or N Pattern Installations
- Replaceable Check Disc Rubber

The Colt C200, C200N Double Check Valve Assemblies are used to prevent backflow of pollutants, that are objectionable but not toxic, from entering the potable water supply system. The Colt C200, C200N may be installed under continuous pressure service and may be subjected to backpressure. The Colt C200, C200N consists of two independently operating check valves, two shutoff valves, and four test cocks. For use in non-health hazard applications.

Specifications

The Colt C200, C200N Double Check Valve Assembly shall consist of two independent Tri-Link Check modules within a single housing, sleeve access port, four test cocks and two drip tight shutoff valves. Tri-Link Checks shall be removable and serviceable, without the use of special tools. The housing shall be constructed of 304 (Schedule 40) stainless steel pipe with groove end connections. Tri-Link checks shall have reversible elastomer discs and in operation shall produce drip tight closure against the reverse flow of liquid caused by backpressure or backsiphonage. Assembly shall be a Colt C200, C200N as manufactured by the Ames Company.

*The wetted surface of this product contacted by consumable water contains less than one quarter of one percent (0.25%) of lead by weight.

Job Name _____ Contractor _____

Job Location _____ Approval _____

Engineer _____ Contractor's P.O. No. _____

Approval _____ Representative _____

Ames product specifications in U.S. customary units and metric are approximate and are provided for reference only. For precise measurements, please contact Ames Technical Service. Ames reserves the right to change or modify product design, construction, specifications, or materials without prior notice and without incurring any obligation to make such changes and modifications on Ames products previously or subsequently sold.

Configurations

- Horizontal
- Vertical up
- “N” pattern horizontal

Materials

- Housing & Sleeve: 304 (Schedule 40) Stainless Steel
- Elastomers: EPDM, Silicone and Buna ‘N’
- Tri-Link Checks: Noryl®, Stainless Steel
- Check Discs: Reversible Silicone or EPDM
- Test Cocks: Bronze Body Nickel Plated
- Pins & Fasteners: 300 Series Stainless Steel
- Springs: Stainless Steel

Available Models

Suffix:

NRS - non-rising stem resilient seated gate valves

OSY - UL/FM outside stem and yoke, resilient seated gate valves

BFG - UL/FM grooved gear operated butterfly valves with tamper switch

*OSY FxG - Flanged inlet gate connection and grooved outlet gate connection

*OSY GxG - Grooved inlet gate connection and flanged outlet gate connection

*OSY GxG - Grooved inlet gate connection and grooved outlet gate connection

Available with grooved NRS gate valves - consult factory*

Post indicator plate and operating nut available - consult factory*

*Consult factory for dimensions

Pressure — Temperature

Temperature Range: 33°F – 110°F (5°C – 43°C)

Maximum Working Pressure: 175psi (12.06 bar)

Dimensions — Weights

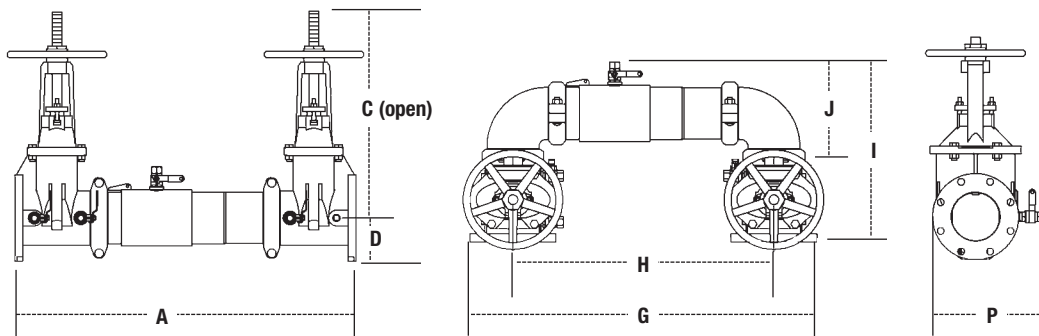

C200, C200N

SIZE (DN)		DIMENSIONS										WEIGHT															
in.	mm	A	C (OSY)	C (NRS)	D	G	H	I	J	P	C200NRS	C200OSY	C200NRS	C200OSY													
		in.	mm	in.	mm	in.	mm	in.	mm	in.	mm	in.	mm	in.	mm	lbs.	kgs.	lbs.	kgs.	lbs.	kgs.						
2½	65	31	787	16¾	416	9¾	238	3½	89	29⅞	738	22	559	15½	393	8⅞	223	9⅞	234	115	52	125	57	123	56	133	60
3	80	31⅞	805	18⅞	479	10¼	260	3⅞	94	30¼	768	22¾	578	17⅞	435	9⅞	233	10½	267	131	59	145	66	144	65	158	72
4	100	33⅞	856	22¾	578	12¾	310	4	102	33	838	24	610	18½	470	9⅞	252	11¾	284	161	73	161	73	184	83	184	83
6	150	43½	1105	30⅞	765	16	406	5½	140	44¾	1137	33¾	857	23¾	589	13⅞	332	15	381	273	124	295	134	314	142	336	152
8	200	50	1270	37¾	959	19⅞	506	6⅞	170	54⅞	1375	40⅞	1032	27⅞	697	15⅞	399	17¾	437	438	199	480	218	513	233	555	252
10	250	57½	1460	45¾	1162	23⅞	605	8⅞	208	66	1676	50	1270	32½	826	17¾	440	20	508	721	327	781	354	891	404	951	431

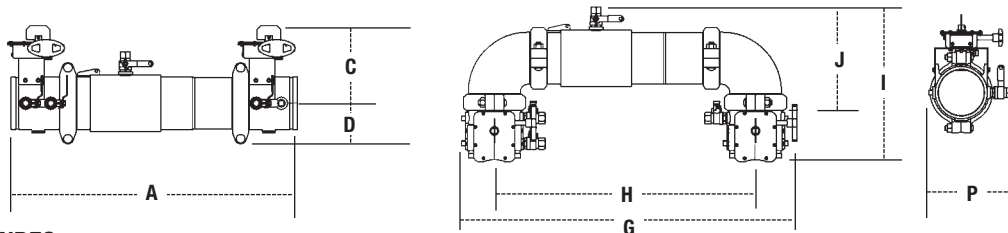

C200BFG, C200NBFG

SIZE (DN)		DIMENSIONS										WEIGHT									
in.	mm	A	C	D	G	H	I	J	P	C200BFG	C200NBFG										
		in.	mm	in.	mm	in.	mm	in.	mm	in.	mm	in.	mm	lbs.	kgs.	lbs.	kgs.				
2½	65	28	711	8	203	3½	89	29⅞	759	22	559	14⅞	379	8⅞	223	9	229	56	25	64	29
3	80	28½	724	8⅞	211	3⅞	94	30⅞	779	22¾	578	15⅞	392	9⅞	233	9½	241	54	24	67	30
4	100	29⅞	741	8⅞	227	3⅞	94	31⅞	811	24	610	16¼	412	9⅞	252	10	254	61	28	84	38
6	150	36½	927	10	254	5	127	43⅞	1097	33¾	857	19⅞	500	13⅞	332	10½	267	117	53	157	71
8	200	43	1092	12¼	311	6½	165	51⅞	1297	40⅞	1032	23⅞	592	15⅞	399	14¾	361	261	118	337	153

Approvals



1015



28S6



B64.4



Approved

For additional approval information please contact the factory or visit our website at www.amesfirewater.com

Capacity

UL/FM Certified Flow Characteristics

Flow characteristics collected using butterfly shutoff valves.

See literature S-Colt-200/300 for gate valve flow characteristics

* = Rated Flow ** = UL Tested

— Horizontal — Vertical - - - - N - Pattern

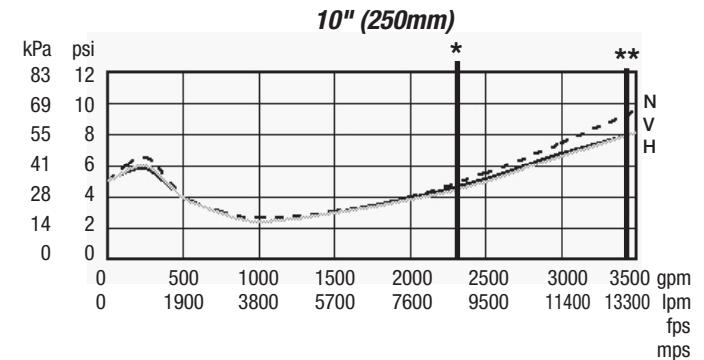
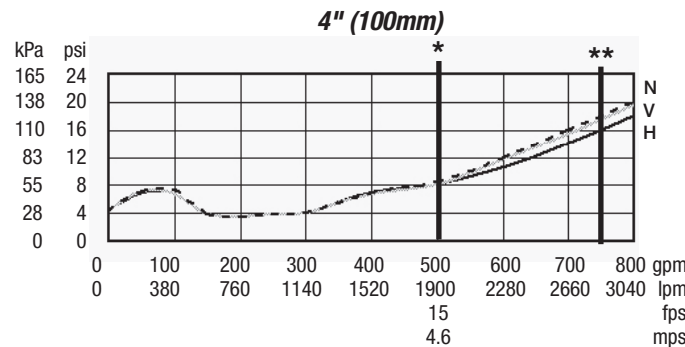
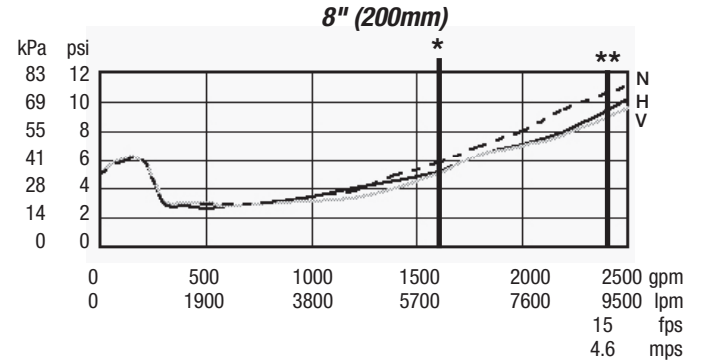
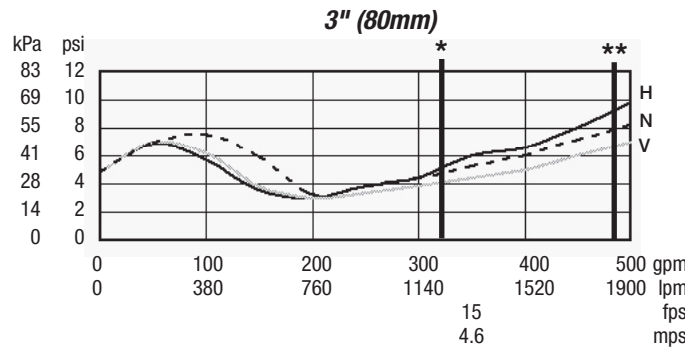
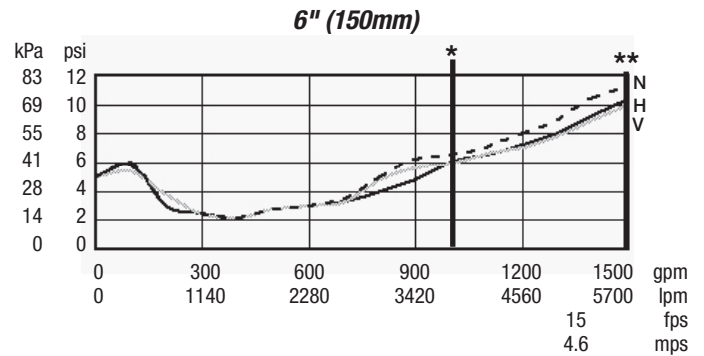
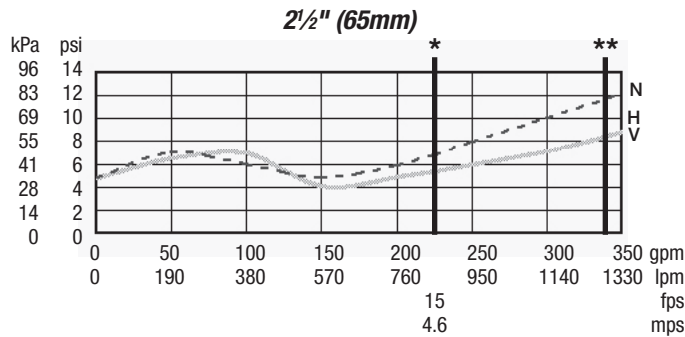

IMPORTANT: INQUIRE WITH GOVERNING AUTHORITIES FOR LOCAL INSTALLATION REQUIREMENTS

For additional information, visit our web site at: www.amesfirewater.com



www.amesfirewater.com



A Watts Water Technologies Company

USA: Backflow- 1427 N. Market Blvd • Suite #9 • Sacramento, CA 95834 • T: 916-928-0123 • F: 916-928-9333

Control Valves- 18550 Hansen Road • Houston, TX 77075 • T: 713-943-0688 • F: 713-944-9445

Canada: 5435 North Service Rd. • Burlington, ONT. L7L 5H7 • T: 905-332-4090 • F: 905-332-7068

ES-A-C200/C200N 0935

© 2009 Ames Fire & Waterworks