



Model 1200

# REMOTE TEST<sup>®</sup>

Remote Operated TESTANDRAIN<sup>®</sup> Valve



1" 1¼" 2"

**Provides Remote System Inspection with Fail Safe Integrity.**

- How **REMOTE TEST<sup>®</sup>** Works: Energizing the solenoid allows system water to flow through a test orifice. After the preset time delay, the water flow alarm is activated, confirming system integrity. No response from the system alarms indicates potential system problems, such as no water flowing in the system, an inoperable water flow alarm, or other system problems which may require site investigation.
- Designed to be integrated into an existing panel or wired to an independent panel allowing **ONE** person to activate each specific system or group of systems from one central location.
- Allows quarterly or more frequent system tests to be performed easily during off-peak hours, requiring considerably less time.
- Ability to manually test each floor individually is unaffected.
- The **REMOTE TEST<sup>®</sup>** is available in 24V DC or 120V AC.
- Available for 1", 1¼", 1½", and 2" with multiple **TESTANDRAIN<sup>®</sup>** orifice sizes available.
- Considered an auxiliary testing device by NFPA, therefore **REMOTE TEST<sup>®</sup>**'s "wiring does not require a supervised circuit".
- **REMOTE TEST<sup>®</sup>** complies with the NFPA 13, 2007 Edition, Chapters 8.16.2.4.1 – 8.16.2.4.4, A.8.17.4.2, 8.17.4.2.2, 8.17.4.2.4, 8.17.4.3.1, and 8.17.4.3.2
- Repair kits including (1) adapter gasket, (1) ball, (2) valve seats, (1) stem packing, and (1) stem washer are available for all **TESTANDRAIN<sup>®</sup>** valves. Valve and orifice size must be specified when ordering.

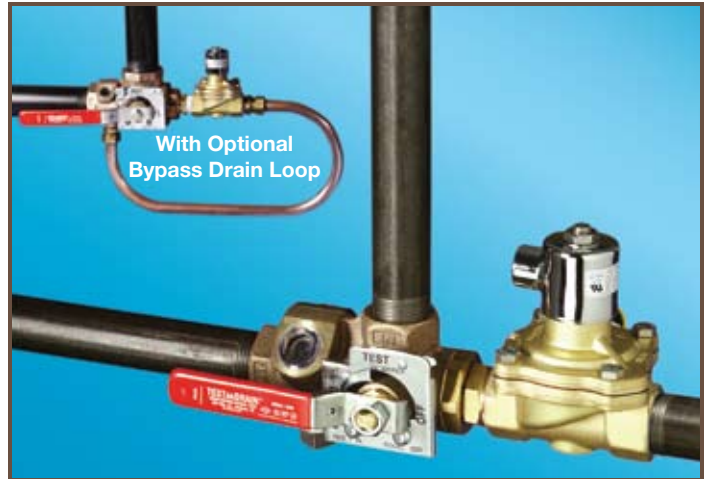

**MODEL 1200 - PLAN VIEW**

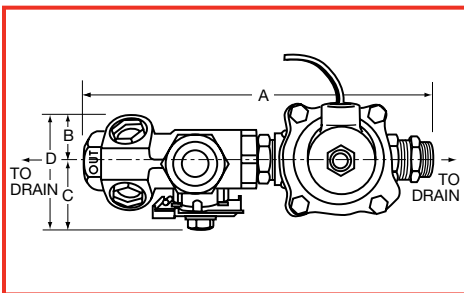

**MODEL 1200 - FRONT VIEW**

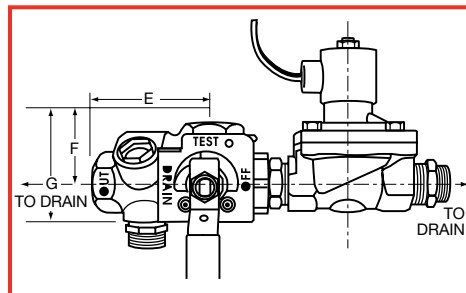

**WITH OPTIONAL BYPASS DRAIN LOOP**

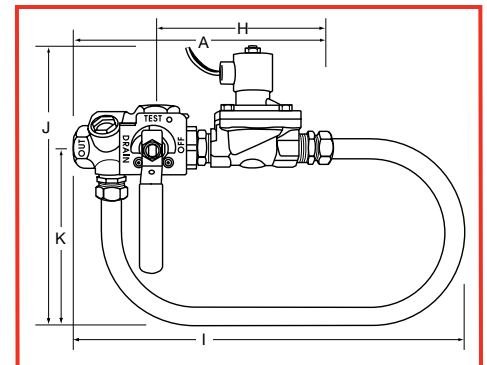

**DIMENSIONS**

Orifice Size Available: 3/8", 7/16", 1/2", 17/32", ELO (5/8"), ESFR (3/4")\*, K25\*\*

SIZE	A	B	C	D	E	F	G	H	I†	J†	K†
1"	9½" (241 mm)	1¾" (45 mm)	2¼" (57 mm)	4" (102 mm)	3¼" (83 mm)	1¾" (45 mm)	6½" (165 mm)	6¼" (159 mm)	18½" (470 mm)	12¾" (324 mm)	8¾" (222 mm)
1¼"	10" (254 mm)	1¾" (45 mm)	3" (72 mm)	4¾" (121 mm)	3¼" (83 mm)	1¾" (45 mm)	7¼" (184 mm)	6½" (165 mm)	18½" (470 mm)	12¾" (324 mm)	8¾" (222 mm)
1½"	11" (279 mm)	1¾" (45 mm)	3¾" (95 mm)	5½" (140 mm)	4" (102 mm)	2¾" (70 mm)	11" (279 mm)	7¼" (184 mm)	18½" (470 mm)	12¾" (324 mm)	8¾" (222 mm)
2"	11" (279 mm)	1¾" (45 mm)	3¾" (95 mm)	5½" (140 mm)	4" (102 mm)	2¾" (70 mm)	11" (279 mm)	7¼" (184 mm)	18½" (470 mm)	12¾" (324 mm)	8¾" (222 mm)

\* Available on 1¼" to 2" size units only \*\* Available on 2" size units only † Refers to Optional Bypass Drain Loop

**Reliability, Versatility, Code Compatibility**



Model 1200

# REMOTE TEST<sup>®</sup>

300 PSI Bronze Ball Valve with Solenoid for Remote Operation

### GENERAL NOTES

1. The **REMOTE TEST<sup>®</sup>** Model 1200 is designed to provide remote functional testing of sprinkler waterflow alarm devices and confirm system viability.
2. The **REMOTE TEST<sup>®</sup>** Model 1200 is considered an auxiliary testing device and, as stipulated in NFPA 72, "the wiring does not require a supervised circuit." Installation shall be in strict conformance with the National Electrical Code (NFPA 70), NFPA 13 and 72, and/or authority having jurisdiction.

### SEQUENCE OF OPERATION

1. Notify the central monitoring station or appropriate authority prior to testing the system.
2. The **REMOTE TEST<sup>®</sup>** Model 1200 is activated by a control panel supplying power to the normally closed solenoid of the **REMOTE TEST<sup>®</sup>**.
3. Once energized, the solenoid of the **REMOTE TEST<sup>®</sup>** opens which flows system water through an orifice. This moves water past the waterflow alarm devices and simulates the flow of a sprinkler. The system will then perform all the output functions associated with an alarm event, such as activating the notification appliances (horn, strobes, etc.),
4. The activation switch can then be returned to the normal position. This will de-energize the **REMOTE TEST<sup>®</sup>**, shut the valve, and stop the flow of system water.
5. The fire panel can then be acknowledged and reset. The system is now ready to test the next waterflow alarm device.
6. The ability to manually operate each **TEST AND DRAIN<sup>®</sup>** valve of the **REMOTE TEST<sup>®</sup>** to activate each waterflow alarm device is unaffected.
7. Once testing has been completed, restore the fire alarm panel and notify the appropriate authority.

### MODEL 1200 VALVE OPERATING INSTRUCTIONS

#### To Manual Test:

1. Turn valve handle counterclockwise from "Off" to "Test". The handle will stop automatically.
2. After test is completed return handle to "Off".

#### To Remote Test:

1. Activate panel controls to open the solenoid of the **REMOTE TEST<sup>®</sup>** to start test.
2. Release panel controls to close the solenoid of the **REMOTE TEST<sup>®</sup>** after test is completed.

#### To Drain:

1. Turn handle counterclockwise from "Off" to "Test". The handle will stop automatically.
2. Depress "Push" button and turn handle to "Drain".
3. When system is empty return handle clockwise to "Off" position.

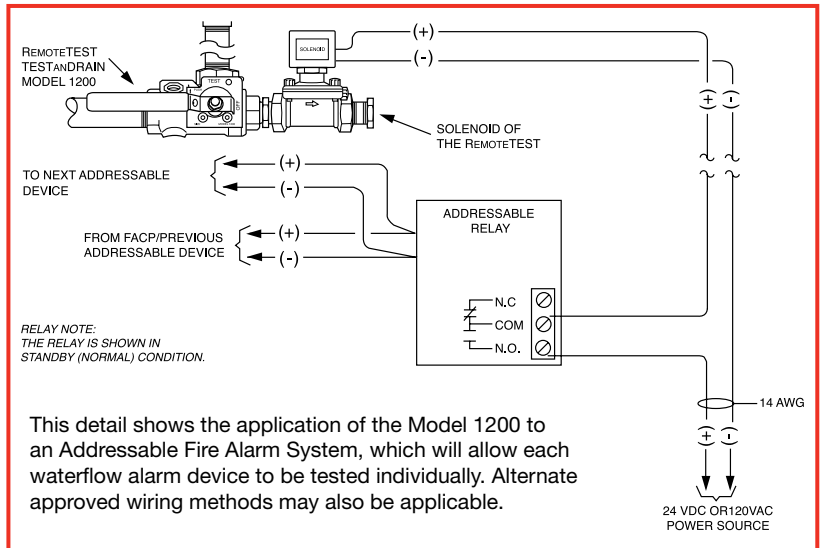
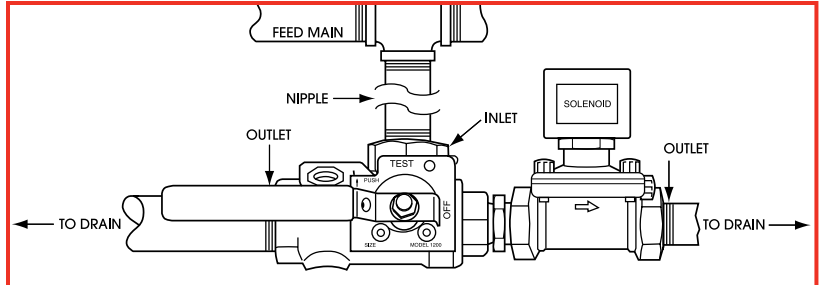

### INSTALLATION INSTRUCTIONS FOR AGF MODEL 1200 REMOTE TEST<sup>®</sup>

1. Check the indicating plate for the correct orifice size. **TEST AND DRAIN<sup>®</sup>** orifices available include 3/8", 7/16", 1/2", 17/32", 5/8", (ELO) and 3/4", (ESFR).
2. Thread pipe nipple into the inlet of the **TEST AND DRAIN<sup>®</sup>**.
3. Thread pipe nipple and the **TEST AND DRAIN<sup>®</sup>** into the outlet of the feed main.
4. Thread piping from outlet of **TEST AND DRAIN<sup>®</sup>** and outlet of the solenoid of the **REMOTE TEST<sup>®</sup>** to an acceptable drain.
5. Wire in accordance with applicable local and national electrical codes. Loosen the hex nut of the solenoid to rotate the coil jacket to desired position to accommodate conduit location. Using a torque wrench, tighten the hex nut to 20-25 inch pounds when installation is complete.



USA Patent # 4741361 and Other Patents Pending



**AGF Manufacturing Inc.**  
 100 Quaker Lane, Malvern, PA 19355  
 Phone: 610-240-4900  
 Fax: 610-240-4906  
 www.testandrain.com

Job Name: \_\_\_\_\_  
 Architect: \_\_\_\_\_  
 Engineer: \_\_\_\_\_  
 Contractor: \_\_\_\_\_