



Model 1011T

TEST AND DRAIN®

Sectional Floor Control Test and Drain Valve for Systems Requiring Pressure Relief Valve and Pressure Gauge Assembly



3/4" 1" 1 1/4" 1 1/2" 2"

- The AGF Manufacturing Inc. **Model 1011T TEST AND DRAIN®** matches all the features and benefits of our **Model 1000** by providing both the test function and the express drain function in a multistory installation for a wet fire sprinkler system, with the added features of an integral **Model 7000 Pressure Relief Valve** with drainage piping, **Model 7500 300 PSI 3 1/2" Pressure Gauge**, and **Model 7600 1/4" 3-Way Globe Valve**.

- The **Model 1011T** complies with the requirements of NFPA-13 that stipulate a pressure relief valve be installed on all gridded systems and downstream of all pressure reducing valves (see reverse).

- The **Model 1011T TEST AND DRAIN®** is a compact single handle ball valve which includes a tamper resistant test orifice and integral tamper resistant sight glasses, and is 300 PSI rated.

- Available in a full range of sizes from 3/4" to 2" NPT and BSPT, with all specifiable orifice sizes 3/8" (2.8K), 7/16" (4.2K), 1/2" (5.6K), 17/32" (8.0K), 5/8" (11.2K, ELO), 3/4" (14.0K, ESFR), and K25 as required by NFPA 13, 2007 (see reverse).

- The included UL/FM **Model 7000 Pressure Relief Valve** features a flushing handle and is factory rated for 175 PSI. Other pressure settings are available and may be substituted.

- Designed to relieve excess system pressure caused by surges or temperature changes as well as solve the difficult problem of providing the relief valve with a convenient drainage-piping outlet.

- The **Model 1011T** is shipped complete with all necessary components including the UL/FM **Model 7500 Pressure Gauge** and UL/FM **Model 7600 Globe Valve**.

- Shipped with relief valve and bypass drain ports plugged to expedite pressure testing the system.

- A locking kit is available and can be ordered with the valve to provide vandal resistance or prevent unintentional alarm activation.

- Repair kits including (1) adapter gasket, (1) ball, (2) valve seats, (1) stem packing, and (1) stem washer are available for all **TEST AND DRAIN®** valves. Valve and orifice size must be specified when ordering.

NOTE: It is important to note that the pressure rating of the relief valve indicates an operating range of pressure for both opening and closing of the valve. Standard relief valves are required to OPEN in a range of pressure between 90% and 105% of their rating. The valves are required to CLOSE at a pressure above 80% of that rating. The relief valve should be installed where it is easily accessible for maintenance. Care should be taken that the relief valve CANNOT be isolated from the system when the system is operational. A relief valve should NEVER have a shutoff valve or a plug downstream of its outlet.

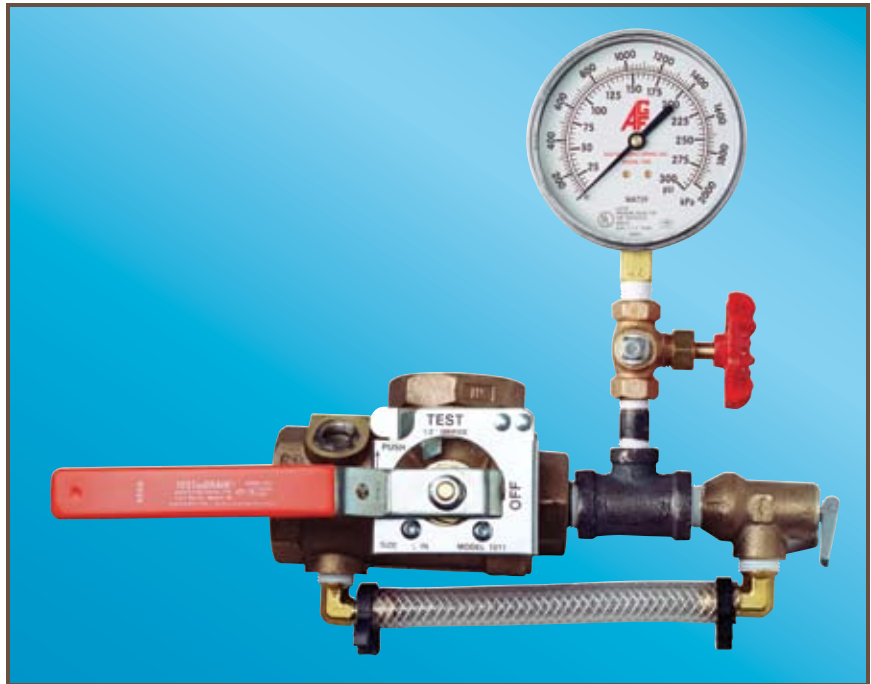

Reliability, Versatility, Code Compatibility



TEST AND DRAIN®

Model 1011T

Model 1011T 300 PSI Bronze Ball Valve, Model 7000 Pressure Relief Valve, Model 7500 Pressure Gauge, and Model 7600 1/4" 3-Way Globe Valve

DIMENSIONS

Orifice Size Available: 3/8", 7/16", 1/2", 17/32", ELO (5/8")*, ESFR (3/4")*, & K25**

SIZE	A	B	C	D	E	F
3/4"	10 1/4" (256 mm)	3 3/8" (86 mm)	11 3/16" (46 mm)	4 9/16" (117 mm)	6 3/8" (162.5 mm)	8 3/4" (119 mm)
1"	10 1/4" (256 mm)	3 3/8" (86 mm)	11 3/16" (46 mm)	4 9/16" (117 mm)	6 3/8" (162.5 mm)	8 3/4" (119 mm)
1 1/4"	10 1/2" (263 mm)	3 5/8" (91 mm)	11 5/16" (51 mm)	5 9/16" (141 mm)	5 1/2" (192 mm)	9" (225 mm)
1 1/2"	11 1/2" (288 mm)	3 7/8" (99 mm)	2 5/8" (67 mm)	8 1/4" (207 mm)	10 7/8" (274 mm)	9 11/16" (242 mm)
2"	11 1/2" (288 mm)	3 7/8" (99 mm)	2 5/8" (67 mm)	8 1/4" (207 mm)	10 7/8" (274 mm)	9 11/16" (242 mm)

* Available on 1 1/4" to 2" size units only

** Available on 1 1/2" and 2" size units only

MODEL 1011T - FRONT VIEW

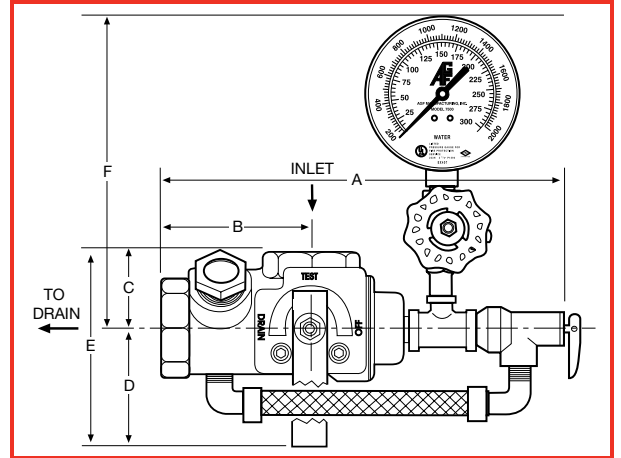

THE MODEL 1011T PROVIDES ALL OF THE FOLLOWING...

From the 2007 Edition of NFPA 13

- Chapter 8.16.2.4.1* Provisions shall be made to properly drain all parts of the system.
- Chapter 8.16.2.4.2 Drain connections, interior sectional or floor control valve(s) – shall be provided with a drain connection having a minimum size as shown in Table 8.16.2.4.2.
- & 8.16.2.4.3
- Chapter 8.16.2.4.4 Drains shall discharge outside or to a drain capable of handling the flow of the drain.
- Chapter A.8.17.4.2 (Wet Pipe System) test connection is permitted to terminate into a drain capable of accepting full flow... using an approved sight test connection containing a smooth bore corrosion-resistant orifice giving a flow equivalent to one sprinkler...
- Chapter 8.17.4.2.2 The test connection valve shall be readily accessible.
- Chapter 8.17.4.2.4 shall be permitted to be installed in any location... downstream of the waterflow alarm.
- Chapter 8.17.4.3.1 (Dry Pipe System) a trip test connection not less than 1" in diameter, terminating in a smooth bore corrosion-resistant orifice, to provide a flow equivalent to one sprinkler...
- Chapter 8.17.4.3.2 The trip test connection... with a shutoff valve and plug not less than 1", at least one of which shall be brass.
- Chapter 7.1.2 - a gridded wet pipe system shall be provided with a relief valve set to operate at 175 PSI or 10 PSI in excess of the maximum system pressure, whichever is greater.
- Chapter 8.16.1.2.3* A relief valve of not less than 1/2" in size shall be provided on the discharge side of the pressure-reducing valve set to operate at a pressure not exceeding 175 PSI.
- Chapter A.8.16.1.2.3 - consideration should be given to piping the discharge from the (pressure relief) valve
- Chapter 8.16.1.2.2 Pressure gauges shall be installed on the inlet and outlet sides of each pressure-reducing valve.

MATERIALS

- Handle: Steel
- Stem: Rod Brass
- Ball: C.P. Brass
- Body: Bronze
- Valve Seat: Impregnated Teflon®
- Indicator Plate: Steel
- Relief Valve: Bronze
- Bypass Fittings: Brass
- Bypass Tubing: Nylobraid

APPROVALS

- UL and ULC Listed: (EX4019 & EX4533)
- FM Approved
- NYC-BSA No. 720-87-SM



USA Patent # 4741361 and Other Patents Pending



AGF Manufacturing Inc.
 100 Quaker Lane, Malvern, PA 19355
 Phone: 610-240-4900
 Fax: 610-240-4906
 www.testandrain.com

Job Name: _____
 Architect: _____
 Engineer: _____
 Contractor: _____