

The Gruvlok 78FP UL/ULC Listed and FM Approved Check Valve is a compact, cost-effective valve, designed for use in grooved-end pipe fire protection systems and related equipment. Valves are to be used in conjunction with grooved pipe and pipe couplings that are listed or approved for fire protection systems.

PRESSURE RATING:

2" through 12" 78FP UL/ULC Listed and FM Approved Check Valves have a maximum working pressure of 300 PSI (20.7 bar).

DESIGN FEATURE:

In a full open position the 78FP UL/ULC Listed and FM Approved rubber faced swing clapper is held tightly against the valve body, out of the flow stream, to provide maximum flow area and prevention of clapper flutter. The spring loaded clapper design produces quick, non-slam closure before flow reversal can occur, which provides a leak free sealing of back pressures as low as 1 PSI (0.07 bar) equivalent to 28" water head, meeting FM requirements for an anti-water-hammer check valves.

APPLICATIONS:

Appropriate for use in fire protection connections such as:

- Fire Department pumper to sprinkler systems
- Public water supplies to automatic sprinkler systems
- Fire pump discharges and by-pass
- Gravity and pressure tanks



For Listing/Approval Details and Limitations, visit our website at www.anvilstar.com or contact an Anvil®/AnvilStar™ Sales Representative.

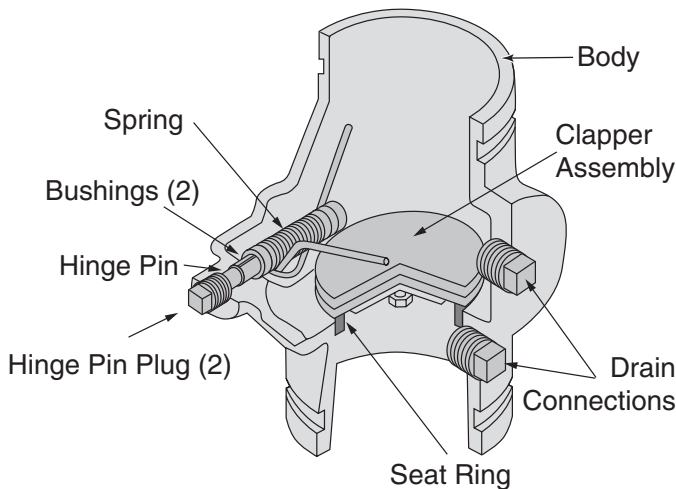

MATERIAL SPECIFICATIONS

BODY: Ductile Iron conforming to ASTM A-536, Grade 65-45-12

COATINGS: Rust inhibiting paint on exterior Color: BLACK

CLAPPER: 2" - 5" Type 304 or 302 Stainless Steel to ASTM A-167
6"-12" Ductile Iron conforming to ASTM A-536, Grade 65-45-12

CLAPPER FACING: Grade "E" EPDM
-40°F to 230°F (Service Temperature Range)(-40°C to 110°C)
Recommended for water service, diluted acids, alkalis solutions, oil-free air and many chemical services.
NOT FOR USE IN PETROLEUM APPLICATIONS.

SEAT RING: Type 304 Stainless Steel conforming to ASTM A-123, ASTM A-213, ASTM-A 312 or ASTM A-269

SPRING: Type 302 Stainless Steel conforming to ASTM A-313

HINGE PIN: Type 304 or 302 Stainless Steel conforming to ASTM A-580

HINGE PIN BUSHINGS: Sintered Bronze conforming to ASTM B-438

HINGE PIN PLUGS AND DRAIN PLUGS: Cast Iron conforming to ASTM A-126 Class A.

PROJECT INFORMATION		APPROVAL STAMP	
Project:		<input type="checkbox"/> Approved	
Address:		<input type="checkbox"/> Approved as noted	
Contractor:		<input type="checkbox"/> Not approved	
Engineer:		Remarks:	
Submittal Date:			
Notes 1:			
Notes 2:			

FLOW DATA:

The approximate friction losses, based on the Hazen and Williams formula, expressed in equivalent length of pipe is given at right. The friction losses have been calculated on the basis of flow rates typically used with each size valve.

IMPORTANT NOTE:

Check valve life may be shortened and system damage may occur if check valves are installed too close to a source of unstable flow. Check valves must be installed at a reasonable distance away from pumps, elbows, expanders, reducers or other similar devices. Sound piping practices dictate a minimum of five (5) times the pipe diameter for general use. Distances between three (3) and five (5) diameters are allowable provided the flow velocity is less than 8 feet per second. Distances less than 3 diameters are not recommended.

Friction Loss Series 78FP Check Valve (Water at 65°F)

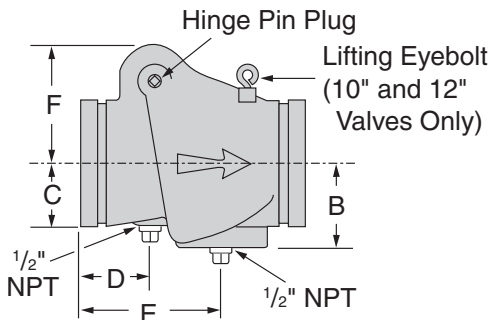
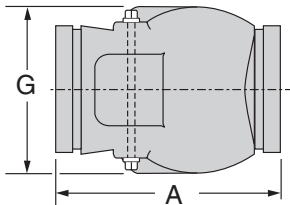
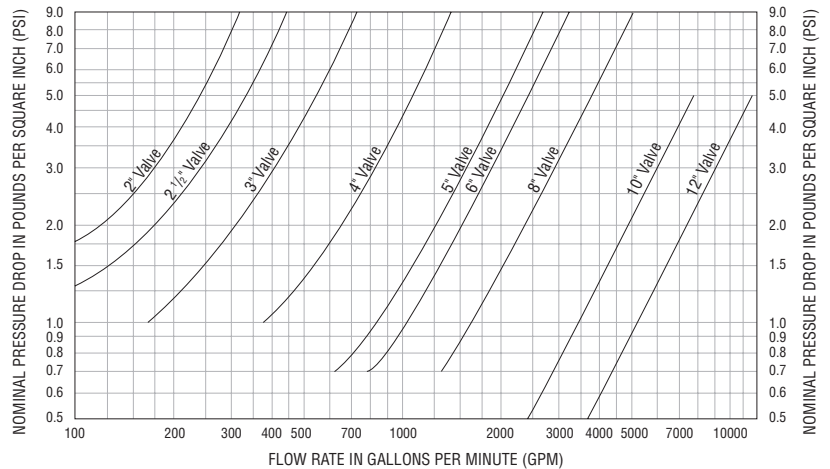

SERIES 78FP CHECK VALVE FLOW DATA - FRICTION LOSS (FT. OF PIPE)							
Valve Size	O.D.	C=100			C=120		
		Sch. 10	Sch. 30	Sch. 40	Sch. 10	Sch. 30	Sch. 40
In./mm	In./mm	Ft./m	Ft./m	Ft./m	Ft./m	Ft./m	Ft./m
2	2.375	10	—	8	14	—	11
50	60.3	3.0	—	2.4	4.3	—	3.4
2½	2.875	14	—	10	20	—	15
65	73.0	4.3	—	3.0	6.1	—	4.6
3	3.500	17	—	12	23	—	17
80	88.9	5.2	—	3.7	7.0	—	5.2
4	4.500	17	—	13	23	—	18
100	114.3	5.2	—	4.0	7.0	—	5.5
5	5.563	14	—	11	20	—	15
125	141.3	4.3	—	3.4	6.1	—	4.6
6	6.625	23	—	19	33	—	26
150	168.3	7.0	—	5.8	10.1	—	7.9
8	8.625	35	32	30	50	45	43
200	219.1	10.7	9.8	9.1	15.2	13.7	13.1
10	10.750	28	25	24	40	36	34
250	273.1	8.5	7.6	7.3	12.2	11.0	10.4
12	12.750	31	28	26	44	39	37
300	323.9	9.4	8.5	7.9	13.4	11.9	11.3

SERIES 78FP CHECK VALVE									
Valve Size	O.D.	Nominal Dimensions							Approx. Wt. Ea.
		A	B	C	D	E	F	G	
In./DN(mm)	In./mm	In./mm	In./mm	In./mm	In./mm	In./mm	In./mm	In./mm	Lbs./Kg.
2	2.375	6¾	2¾	1⅞	1¾	4½	3⅞	4¾	7.5
50	60.3	171	60	36	44	114	81	111	3.4
2½	2.875	7¼	2⅞	1⅞	1¾	3⅞	3¾	4½	10.5
65	73.0	184	61	39	44	96	92	114	4.8
3	3.500	7¾	2¾	2	1⅞	4⅞	3⅞	4⅞	11.5
80	88.9	197	67	51	46	103	93	125	5.2
4	4.500	8⅞	3¾	2¼	2½	5⅞	4¼	6	13.5
100	114.3	206	79	57	64	128	108	152	6.1
5	5.563	9¾	3½	2¼	2⅞	5⅞	4¾	6¾	19.0
125	141.3	248	89	70	61	147	117	171	8.6
6	6.625	12¾	4¼	3⅞	3⅞	6¼	6¾	8½	33.5
150	168.3	324	108	84	79	159	171	216	15.2
8	8.625	14¾	5⅞	3⅞	4	5⅞	8	10¼	59.0
200	219.1	365	128	100	102	150	203	260	26.8
10	10.750	18	6⅞	4⅞	4⅞	6⅞	9⅞	12⅞	130.0
250	273.1	457	160	125	115	175	233	322	59.0
12	12.750	21	7⅞	6	5⅞	7¼	10¾	14¾	183.0
300	323.9	533	185	152	128	184	264	375	83.0