



Series 2000SS

Double Check Valve Assemblies

Sizes: 2½" – 12" (65 – 300mm)

LEAD FREE*

Features

- Patented Cam-Check Assembly provides low head loss
- Short lay length is ideally suited for retrofit installations
- Stainless Steel body is half the weight of competitive designs reducing installation and shipping cost
- Stainless steel construction provides long term corrosion protection and maximum strength
- Single top access cover with two-bolt grooved style coupling for ease of maintenance
- No special tools required for servicing
- Compact construction allows for smaller vaults and enclosures
- May be installed in horizontal or vertical "flow up" position

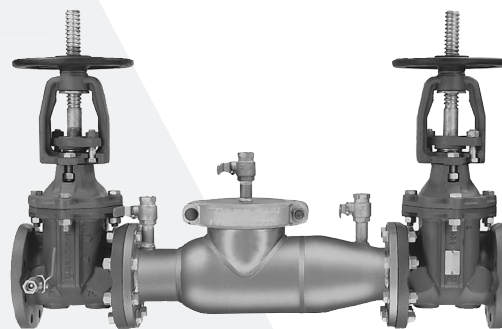

2000SS

Series 2000SS Double Check Valve Assemblies are designed to prevent the reverse flow of polluted water from entering into the potable water system. This series can be applied, where approved by the local authority having jurisdiction, on non-health hazard installations. Features short end-to-end dimensions, lightweight stainless steel body, and low head loss.

Specifications

A Double Check Valve Assembly shall be installed at each noted location to prevent the unwanted reversal of polluted water into the potable water supply. The main valve body shall be manufactured from 300 series stainless steel to provide corrosion resistance, 100% lead free through the waterway. The double check shall consist of two independently operated spring loaded cam-check valves, required test cocks, and optional inlet and outlet resilient seated shutoff valves. Each cam-check shall be internally loaded and provide a positive drip tight closure against the reverse flow of liquid caused by backsiphonage or backpressure. The modular cam-check includes a stainless steel spring and cam-arm, rubber faced disc and a replaceable seat. There shall be no brass or bronze parts used within the cam-check valve assembly. The valve cover shall be held in place through the use of a single grooved style two-bolt coupling. The main assembly shall consist of two independently operating torsion spring check assemblies, two resilient seated isolation valves, and four ball valve type test cocks. The assembly shall be an Ames Company Series 2000SS.

Available Models

Suffix:

NRS – non-rising stem resilient seated gate valves

OSY – UL/FM outside stem and yoke resilient seated gate valves

**OSY FxG – flanged inlet gate connection and grooved outlet gate connection

**OSY GxF – grooved inlet gate connection and flanged outlet gate connection

**OSY GxG – grooved inlet gate connection and grooved outlet gate connection

LG – less gates

Available with grooved NRS gate valves - consult factory**

Post indicator plate and operating nut available – consult factory**

**Consult factory for dimensions

*The wetted surface of this product contacted by consumable water contains less than one quarter of one percent (0.25%) of lead by weight.

Materials

All internal metal parts: 300 Series stainless steel

Main valve body: 300 Series stainless steel

Check assembly: Noryl®

Flange dimension in accordance with AWWA Class D

Noryl® is a registered trademark of General Electric Company.

Pressure — Temperature

Temperature Range: 33°F – 110°F (5°C – 43°C)

Maximum Working Pressure: 175psi (12.06 bar)

Standards

AWWA C510-92, CSA B64.5

Approvals



1015

(OSY ONLY)

For 12" approvals consult factory

Job Name _____ Contractor _____

Job Location _____ Approval _____

Engineer _____ Contractor's P.O. No. _____

Approval _____ Representative _____

Ames product specifications in U.S. customary units and metric are approximate and are provided for reference only. For precise measurements, please contact Ames Technical Service. Ames reserves the right to change or modify product design, construction, specifications, or materials without prior notice and without incurring any obligation to make such changes and modifications on Ames products previously or subsequently sold.

Capacities

Rated working pressure 175psi (12.06 bar) * Rated flow **UL Tested

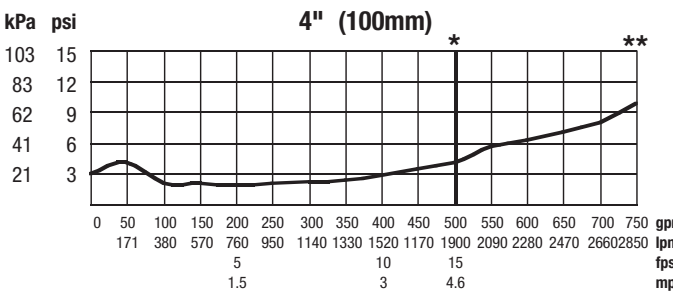
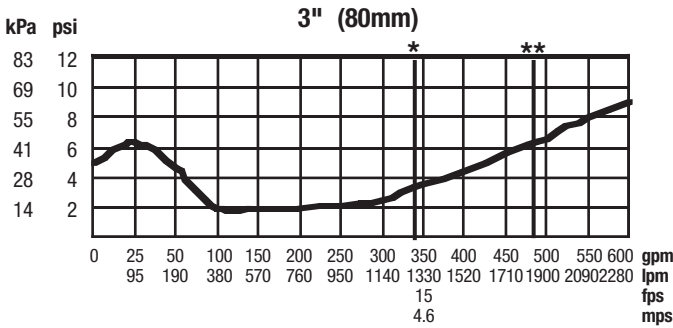
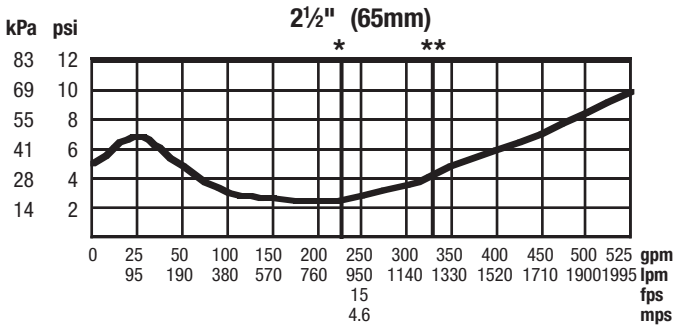

Dimensions — Weights

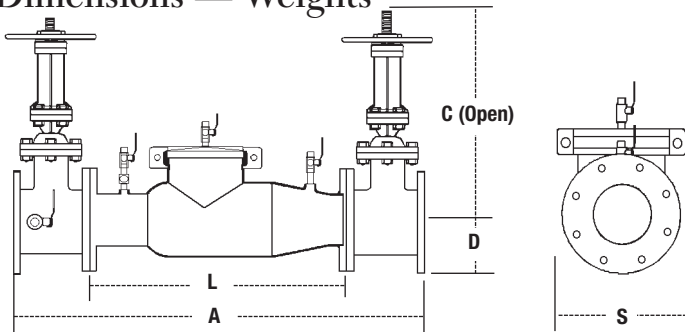

SIZE (DN)		DIMENSIONS										WEIGHT					
in.	mm	A		C (OSY)		C (NRS)		D		L		S		w/Gates		w/o Gates	
		in.	mm	in.	mm	in.	mm	in.	mm	in.	mm	in.	mm	lb.	kg.	lb.	kg.
2½	65	37	965	16¾	416	9¾	238	3½	89	22	559	7	178	140	64	53	24
3	80	38	965	18¾	479	10¼	260	3¾	95	22	559	7½	191	215	98	55	25
4	100	40	1016	22¾	578	12¾	310	4½	114	22	559	9	229	225	102	58	26
6	150	48½	1232	30¾	765	16	406	5½	140	27½	699	11	279	375	170	105	48
8	200	52½	1334	37¾	959	19½	506	6¾	171	29½	749	13½	343	561	254	169	77
10	250	55½	1410	45¾	1162	23¾	605	8	200	29½	749	16	406	763	346	179	81
12	300	57½	1461	53¾	1349	26¾	679	9½	241	29½	749	19	483	1033	469	209	95



www.amesfirewater.com



A Watts Water Technologies Company

USA: Backflow- 1427 N. Market Blvd • Suite #9 • Sacramento, CA 95834 • T: 916-928-0123 • F: 916-928-9333

Control Valves- 18550 Hansen Road • Houston, TX 77075 • T: 713-943-0688 • F: 713-944-9445

Canada: 5435 North Service Rd. • Burlington, ONT. L7L 5H7 • T: 905-332-4090 • F: 905-332-7068

ES-A-2000SS 0934

© 2009 Ames Fire & Waterworks

